

Roll Type Holders and Type

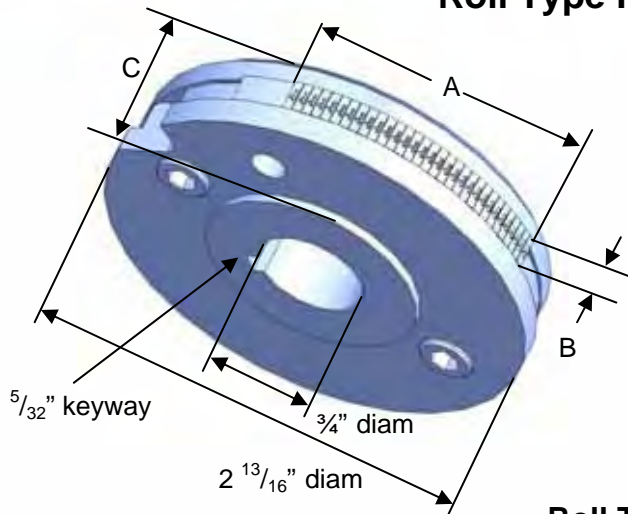

COLUMBIA roll type holders, developed to efficiently mark both flat and contoured surfaces, are designed to hold individual step style wedge type or combinations of wedge type, logo-type, and segment dies. The step in the cover plate retains the type in the holder while a take-up plate, provided with each holder, holds the type in perfect alignment.

The hub extends 1/16" past the cover plate allowing the plate to be released while the holder remains firmly locked in the carriage.

Release of the cover plate allows all type changing operations to be carried out while the holder remains in the carriage, a truly time-saving feature.

Roll Type Holders

Catalog No.	Character Sizes	Dim.			Use in Roll Carriage Cat. No.
		A	B	C	
RMA-2	1/32 1/16	7/32	2	3/4	CA-75
RMA-3	3/32 1/8	7/32	3	3/4	DCA-75
RMB-2	5/32 3/16	9/32	2	1	CA-100
RMB-3		9/32	3	1	DCA-100
RMC-2	1/4	11/32	2	1	CA-100
RMC-3		11/32	3	1	DCA-100

COLUMBIA wedge type is designed to fit into our series RM roll type holders. The step style was selected for our standard type because of the additional strength afforded by this proven design. Blank spacers are required where number of characters needed is less than capacity of holder slot. Style W standard wedge type has a wedge angle generated by a 3" marking diameter.

Wedge Style CMW Series

Character Size	Dimensions			Use in Holder No.	Catalog No.
	A	B	C		
1/32	1/16	1/4	7/32	RMA-2 or 3	CMW03
1/16	1/16	1/4	7/32		CMW06
3/32	3/32	1/4	7/32		CMW09
1/8	1/8	1/4	7/32		CMW13
5/32	3/16	5/16	9/32	RMB-2 or 3	CMW16
3/16	3/16	5/16	9/32		CMW19
1/4	1/4	3/8	11/32	RMC-2 or 3	CMW25

