



**Single Blow Air Hammer Model 95 Pow-r-Mark  
Operation Guide**

**Mounting/Air Connection: Hand Held-**

There is one air port location on the model 95 hand held Pow-r-mark. This air port location is on the back end of the unit where the valve is located.

**Model 95 Operating Instructions:**

**To Mark:** Make sure you align centerline of marker 90° (square) to the marking surface to assure that all characters on the stamp are in contact with the marking surface. Then quickly actuate lever. Marker fires internally.

**To Reset:** Reset is instantaneous, release the actuating lever and marker is ready for the next cycle.

**Air requirements** – Model 95 is a pneumatic powered device. CMT recommends a 3/8” minimum shop airline, and each unit should be installed with its own FRL (Filter Regulator Lubricator). Maximum operating pressure of 80psi, minimum operating pressure 20 psi.

**Adjustments:**

**Mark Depth-** To Regulate marking pressure adjust FRL (Filter/Regulator/Lubricator unit) (Sold separately), increase air pressure to mark deeper and decrease air pressure to mark lighter.

**Maintenance:**

Shut off all air prior to performing any and all maintenance.

**CMT FRL Unit:**

Lubrication – add oil as needed

- Add 30W “light” industrial hydraulic oil to lubricator bowl
- Adjust oil flow to approximately 1 drop for every 30-50 cycles

Air filter – check and clean/change as required  
Frequency of cleaning/changing is dependent on environment and plant air system. Do not allow excess water to fill filter bowl, drain as needed.

Please note a Filter/Regulator/Lubricator unit is recommended by CMT. If you do not purchase a FRL unit from CMT you will need supply one.

Columbia POW-R-MARK	
Model/Feature	Symbol
95	95
Rod Style A (CMG type)	OA
Rod Style B (round insert)	OB
Rod Style N (for holder)	ON



95 N Holder CMG Style Type Capacity									
Holder Model	A	B	1/16	3/32	1/8	5/32	3/16	1/4	
95NA-50	.25	.50	8	5**	4	2*			
95NA-75	.25	.75	12	8	6	4**			
95NB-75	.31	.75				4*	4		
95NC-50	.38	.50							2

\*Use CMG16W groove type  
\*\*Requires use of blank spacer to fill out pocket



**Single Blow Air Hammer Model 95 Pow-r-Mark  
Operation Guide**

**CMG Standard Groove Type  
for use in A style rods**

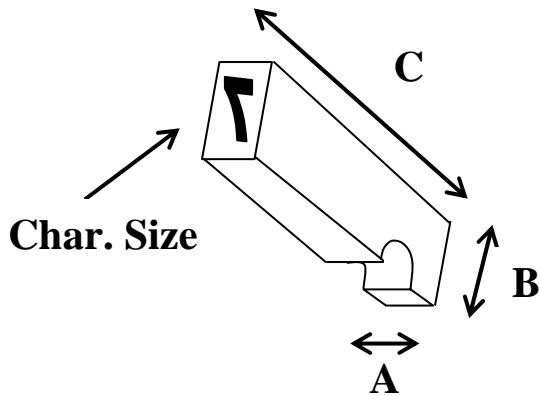

<b>STYLE G Groove Type</b>				
<b>Char Size</b>	<b>A</b>	<b>B</b>	<b>C</b>	<b>Catalog No.</b>
<b>1/32</b>	1/16	1/4	7/8	CMG03-
<b>1/16</b>	1/16	1/4	7/8	CMG06-
<b>3/32</b>	3/32	1/4	7/8	CMG09-
<b>1/8</b>	1/8	1/4	7/8	CMG13-
<b>5/32</b>	3/16	5/16	7/8	CMG16-

<b>CM8X Round Insert</b>	
<b>Char Size</b>	<b>Catalog No.</b>
<b>1/32</b>	CM8X03-
<b>1/16</b>	CM8X06-
<b>3/32</b>	CM8X09-
<b>1/8</b>	CM8X13-
<b>5/32</b>	CM8X16-
<b>3/16</b>	CM8X19-
<b>1/4</b>	CM8X25-

**CM8X Standard Round Type  
for use in B style rods**

